

SPECIFICATIONS
FOR
MAGNETIC CARD READER
Manual Slide type

Z U - M 1 1 2 1 □ 1

OCT. 1991

MATSUSHITA INDUSTRIAL EQUIPMENT CO., LTD.
ELECTRONIC EQUIPMENT DIV.
1-1, 3-Chome, Inazu-cho, Toyonaka
Osaka 561, JAPAN

CONTENTS

1. INTRODUCTION	-----	1
2. PRODUCT NAME	-----	1
3. FUNCTION	-----	1
4. EQUIPMENT SPECIFICATION	-----	1
5. BASIC FEATURES	-----	1
6. CARD STANDARD	-----	2
7. CIRCUIT CONSTRUCTION	-----	3
8. ENVIRONMENTAL CHARACTERISTICS	-----	5
9. UNIT LIFE AND RELIABILITY	-----	6
10. PERIOD OF GUARANTEE	-----	6
11. MAINTENANCE	-----	6
12. HANDLING PRECAUTIONS	-----	6
13. APPEARANCE	-----	8

1. INTRODUCTION

This specification describes about manual slide type magnetic card reader, featuring small size, light weight and high performance which enable to read card data encoded by following ISO2 standard.

2. PRODUCT NAME

2. 1 Product Name : Manual slide type magnetic card reader
2. 2 Model No. :

1 2 3 4 5 6 7 8 9 10
Z U — M 1 1 2 1 1

Magnetic head specification(S:standard)
(L:Long life)

3. FUNCTION

3. 1 Card operation :One way (Refer to appearance)
3. 2 Read/Write :Read only

4. EQUIPMENT SPECIFICATION

4. 1 Out dimension :90mm(L) × 25mm(W) × 24mm(H)
4. 2 Weight :Approximately 25g
4. 3 Supplied voltage
(1) Supplied voltage :+5VDC ± 10% / Lipple(Less than 50mVp-p)
(2) Current consumption :TYP. 3mA, MAX. 6mA
(3) Maximum applied voltage :+7VDC
4. 4 Connector :Molex-Japan Co.,Ltd.53261-0690(Refer to 7.5)
4. 5 Environment requirement :At indoor

5. BASIC FEATURES

5. 1 Card operating speed : 8~150 cm/sec
5. 2 Magnetic head
(1) Numbers of channel : 1
(2) Core width : 1.5mm
(3) Core material : Permalloy(S:Standard)
 Sendust (L:Long life)

6. CARD STANDARD

6. 1 Card standard

Card Standard	ISO
	Track 2nd
Recording density	75 BPI
Recording capacity	40 Characters (5bit code)
Recording method	FM

Track 2nd... ISO 2 (ABA) : American Bankers Association Standard

6. 2 Location of tracks

ISO (1 Track) ISO 7810, ISO 7811

Coercive force(Hc): 300 ~ 3000(Oe)

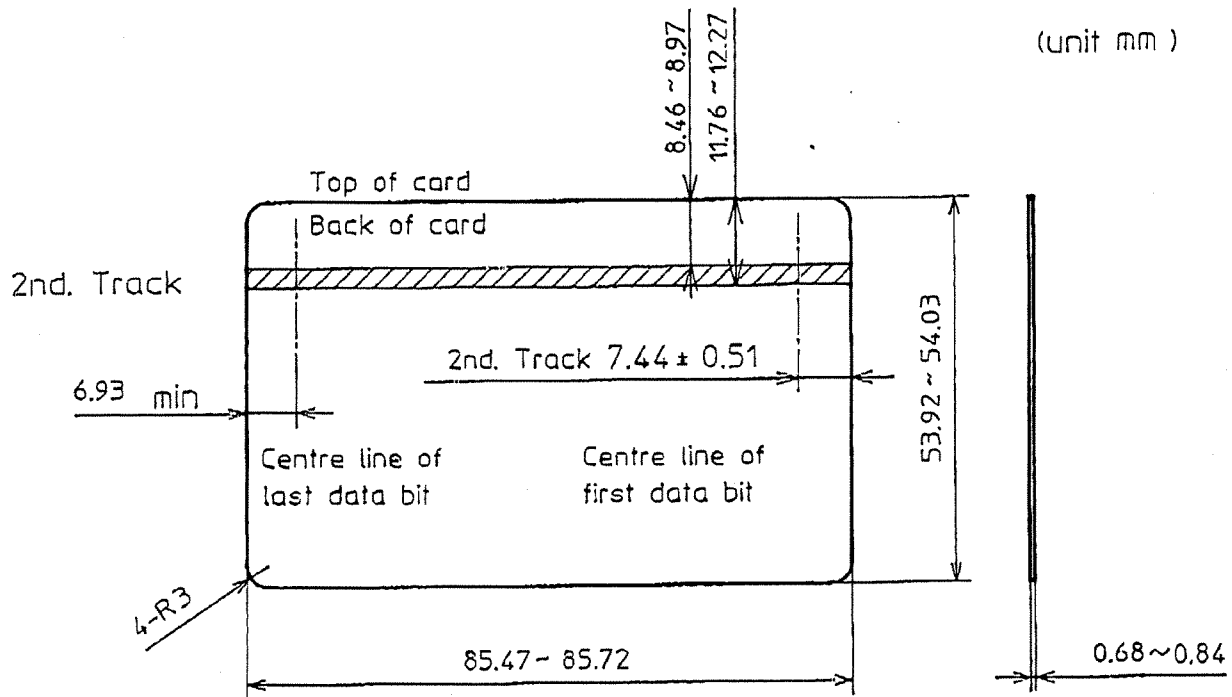

Fig.6.2 Location of tracks

7. CIRCUIT CONSTRUCTION

7. 1 Block diagram

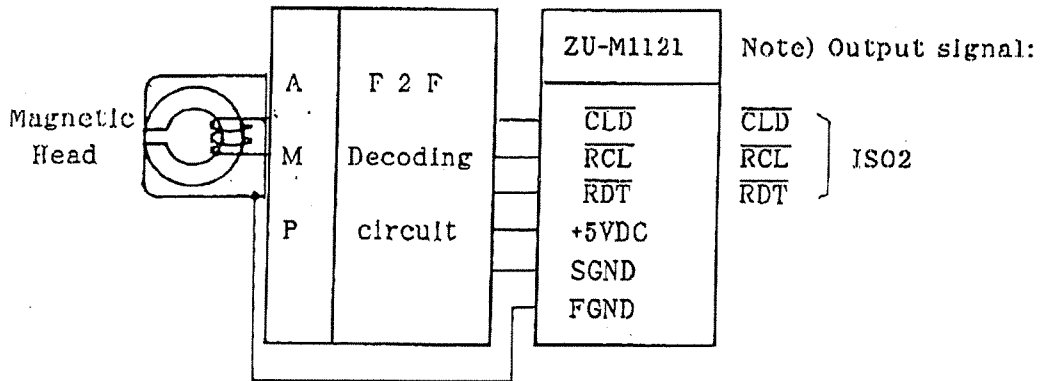

Fig 7.1 Block diagram

7. 2 Interface requirement

- (1) Signal Level : CMOS level
- (2) Signal Logic : Low active
- (3) Connection condition

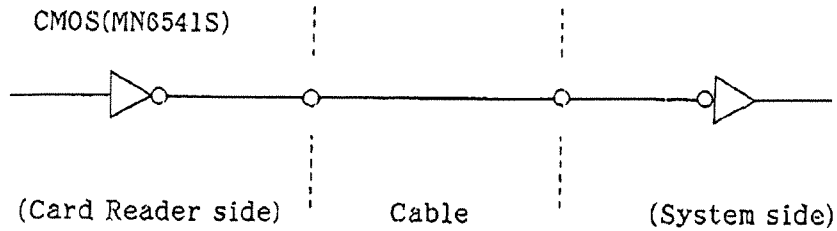

Fig 7.2 Connection of output circuit

- (4) Output voltage

Table 7.2 Output voltage

	Min(V)	Max(V)	Conditions
H level "0"	4.0	V _{CC}	I _{OH} = -1.0mA
L level "1"	-	0.4	I _{OL} = 4.0mA

7. 3 Explanation of input/output signal

Input/output signals are \overline{CLD} , \overline{RCL} , \overline{RDT} , $SGND$, $FGND$ and effective operation Mode for each of these signals shall be " L " level for all.

- (1) \overline{CLD} (CARD LOAD) : The \overline{CLD} line will be Low when a Magnetic Card is running in the Magnetic Card Reader. The \overline{CLD} line will be High when the Card is stopped or not present in the Card reader.
- (2) \overline{RCL} (READ CLOCK): This is used to sample the data line by it's falling edges. The time relationship of the clock with respect to the order signals is shown in Figure 7.4.
- (3) \overline{RDT} (READ DATA) : At the moment \overline{RCL} change from High to Low; \overline{RDT} is " 1 " when the \overline{RDT} line is Low , and \overline{RDT} is " 0 " when the \overline{RDT} line is High.
- (4) $SGND$: Signal GND
- (5) $FGND$: Frame GND

7. 4 Output signal timing chart

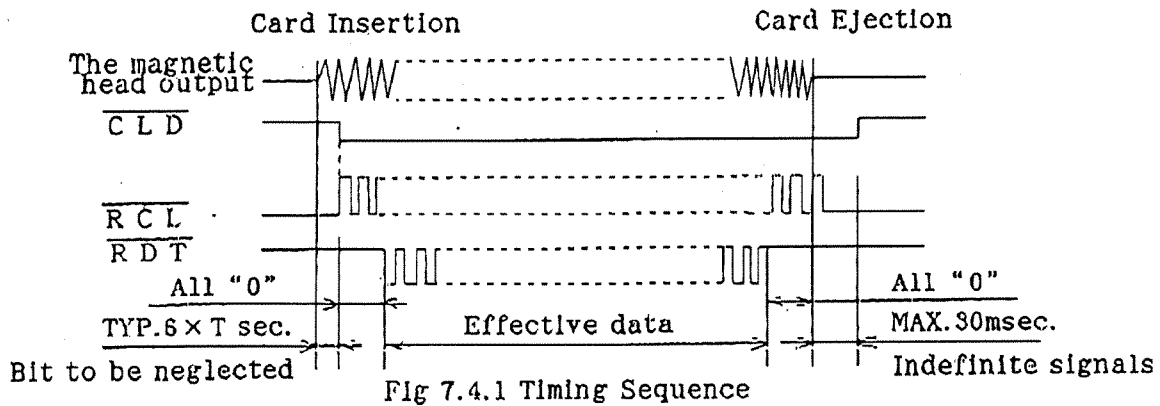

\overline{RCL} & \overline{RDT} Detail timing chart

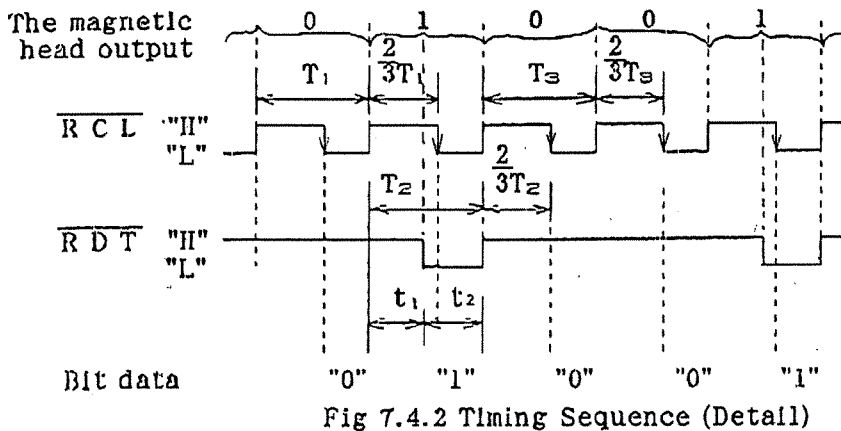

When the jitter of the magnetic head output is 0%, the following equation is satisfied.

$$T = T_1 = T_2 = T_3$$

$$t_1 = t_2$$

$$T \text{ (sec)} = \frac{2.54 \text{ cm/inch}}{\text{Recording density (BPI)}} \cdot \frac{1}{\text{Card speed (cm/sec)}}$$

7. 5 Terminal No. of connector
 (1) Maker : Molex-Japan Co.,Ltd.
 (2) Model No. Connector 53261-0690 (Connect for PC. Board)
 Housing 51021-0600
 Terminal 50079-8000
 (3) Pin No. & Signal Name

ZU-M1121 (Card reader side)

Connector Pin No.	Signal Name
1	FGND
2	SGND
3	+5VDC
4	$\overline{\text{RDT}}$
5	$\overline{\text{RCL}}$
6	$\overline{\text{CLD}}$

Note) : Make sure to use the connection cable of less than 300mm length for the card reader.

8. ENVIRONMENTAL CHARACTERISTICS

8. 1 Operating Temperature Range : -20 ~ 60°C
 8. 2 Operating Humidity Range : 10 ~ 90%RH (No condensation allowed)
 8. 3 Storage Temperature Range : -30 ~ 70°C
 8. 4 Storage Humidity Range : 10 ~ 95%RH (No condensation allowed)
 *Place the card reader in the standard environment
 (temperature: 20 ± 5°C, humidity: 35 to 60%RH). Leave it for 12 hours,
 and measure the functions. Make sure no abnormality is found.
 8. 5 Vibration : Vibration sweep 10 ~ 50 Hz/mm
 X, Y, Z directions
 8. 6 Shock durability : 30G
 8. 7 Others : Make sure the source of noise that
 may deteriorate the characteristics
 of the card reader is not present
 around the card reader.

9. UNIT LIFE AND RELIABILITY

9. 1 Life Magnetic head : 300,000 times pass (S:Standard)
: 1,000,000 times pass (L:Long life)

(conditions) In a clean office room.

In damp or dirty atmosphere, the life may be 1/3 to 1/5 of the above figure.

9. 2 Error rate : Less than 0.1%

(conditions) This error rate is obtained when a new normal card(data "1010" . . .)is horizontally passed at the standard speed (30~60cm/sec.)by manual operation in the clean environment at delivery from our company.

10. PERIOD OF GUARANTEE

If defects should occur within one year after acceptance inspection of the machine due to improper material or workmanship, the defective parts shall be replaced or repaired, free of charge.

11. MAINTENANCE

Because of difficulty at changing components on the P.C Board, replace of whole unit is recommended for service and maintenance.

12. HANDLING PRECAUTIONS

12. 1 Mounting method

- (1) Mount on a flat surface, with due care not to apply excessive force on the card reader main body.
- (2) When mounting on the equipment, take due care so that faces of the constructive device except for the attaching face shall not contact the flexible printed circuit board.
- (3) The controllability is most stable when installed so that the card may run in the vertical direction.
- (4) The controllability will be further stabilized when card guide plates are installed before and after the card running part of the card reader.

12. 2 Handling method

- (1) Since the reading performance depends on the card inserting direction, insert correctly in the specified direction.
The inserting direction is specified in the outline drawing of the specification.
If the card is inserted obliquely, the contact of the card and magnetic head is poor, and it may lead to reading error.
- (2) When inserting the card, the card hits against the head and the action may be dull only for a moment to cause reading error.
It must be noted that this phenomenon is likely to occur when the card is inserted slowly.
- (3) As for card running speed, manipulate within specified speed range.
It may result in an error if card operation is interrupted or extremely accelerated or decelerated. A stable card handling speed by man is usually 30 to 60 cm/sec.

1 2 . 3 Cautions

- (1) Use specified card.(ISO)
Use the card with the coercive force of 300~3000 Oe for ISO.
- (2) Store the card carefully so as not to soil, injure or deform it.
In particular, deposit of solid matter on the magnetic stripe surface may result in a trouble.
- (3) To prevent wear of the magnetic head, clean the head by periodically passing a cleaning card.
For example, in a clean office room, pass the cleaning card about once a week. If the magnetic head is heavily stained, clean the head by soaking the felt part of the cleaning card in alcohol properly.
- (4) When installing the card reader, avoid dusty, hot or damp place, or near magnetic field or object generating inductive noise (printer, LED display unit, CRT, etc.).
Do not use in a place exposed to direct sunlight.
- (5) When storing, pay attention to dust, heat, humidity and other environmental conditions.
- (6) Do not touch the printed circuit board with bare hand.
Note particularly static electricity.
- (7) Do not touch the flexible printed circuit board with hands.
- (8) Do not supply power from other outlet than connector.
Pay special attention to the polarity of power source and wrong connection of connector.
- (9) Check the noise, static electricity, etc., with the card reader being incorporated in the equipment.

13. APPEARANCE

ZU-M1121*1

