

INCH-POUND

MIL-PRF-83421/1D

27 March 2009

SUPERSEDING

MIL-PRF-83421/1C

24 January 2006

PERFORMANCE SPECIFICATION SHEET

CAPACITORS, FIXED, METALLIZED PLASTIC FILM DIELECTRIC, DC AND AC,
HERMETICALLY SEALED IN METAL CASES,
ESTABLISHED RELIABILITY
STYLES CRH01, CRH02, CRH03, CRH04, CRH05, CRH06,
CRH07, CRH08, CRH09, AND CRH00

This specification sheet is approved for use by all Departments
and Agencies of the Department of Defense.

The requirements for acquiring the product described herein
shall consist of this specification sheet and [MIL-PRF-83421](#).

STYLES CRH06 THROUGH CRH00 INACTIVE FOR DESIGN
AFTER 4 JANUARY 1980. USE CRH01 THROUGH CRH05

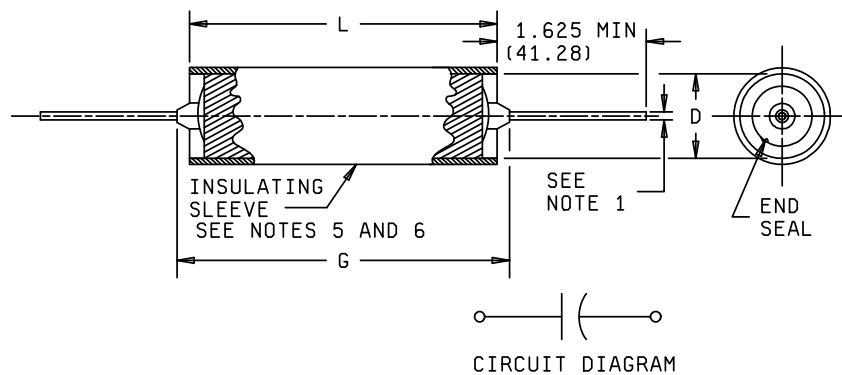

NOTES:

1. Number 22 AWG wire (.025 inch \pm .002 (0.64 mm \pm 0.05)) for case diameters of .312 (7.92 mm) and less. Number 20 AWG wire (.032 inch \pm .002 (0.81 mm \pm 0.05)) for case diameters of .400 (10.16 mm) and .500 (12.70 mm). Number 18 AWG wire (.040 inch \pm .002 (1.02 mm \pm 0.05)) for case diameters of .562 (14.27 mm) and over.
2. Dimensions are in inches.
3. Metric equivalents in parenthesis are given for general information only.
4. See [table I](#) for additional dimensions.
5. Insulating sleeve shall extend beyond the capacitor body. Insulating sleeve thickness shall not exceed .005 (0.13 mm) inch.
6. Plastic insulating sleeve shall be transparent; marking shall be applied to the capacitor case.
7. Lead length may be a minimum of one inch (25.4 mm) long for use in tape and reel packaging, when specified in the ordering data.

FIGURE 1. Capacitor configuration.

TABLE I. Electrical characteristics, dimensions, and dash numbers.

CRH01 AND CHR06 - 30 volts (DC rating)															
Capacitance value (nom) (in µf)	Dimensions ^{1/} (in inches with mm in parentheses)			Dash numbers ^{2/}						AC ratings (for sinusoidal operation from -65 to +100°C) ^{3/}					
	L ±.030 (0.76)	D +.020 (0.51) -.010 (0.25)	G, max	Capacitance tolerance value (in %)						0 to .4 kHz		At 4 kHz		At 40 kHz	
				±0.25	±0.5	±1.0	±2.0	±5.0	±10.0	Volts	Current (in A)	Volts	Current (in A)	Volts	Current (in A)
0.001	0.500 (12.70)	0.170 (4.32)	0.700 (17.78)	-001-	-002-	-003-	-004-	-005-	-006-	22.0	.001	22.0	.001	22.0	.006
0.0012	0.500 (12.70)	0.170 (4.32)	0.700 (17.78)	-007-	-008-	-009-	-010-	-011-	-012-	22.0	.001	22.0	.001	22.0	.007
0.0015	0.500 (12.70)	0.170 (4.32)	0.700 (17.78)	-013-	-014-	-015-	-016-	-017-	-018-	22.0	.001	22.0	.001	22.0	.008
0.0018	0.500 (12.70)	0.170 (4.32)	0.700 (17.78)	-019-	-020-	-021-	-022-	-023-	-024-	22.0	.001	22.0	.001	22.0	.010
0.002	0.500 (12.70)	0.170 (4.32)	0.700 (17.78)	-025-	-026-	-027-	-028-	-029-	-030-	22.0	.001	22.0	.001	22.0	.011
0.0022	0.500 (12.70)	0.170 (4.32)	0.700 (17.78)	-031-	-032-	-033-	-034-	-035-	-036-	22.0	.001	22.0	.001	22.0	.012
0.0027	0.500 (12.70)	0.170 (4.32)	0.700 (17.78)	-037-	-038-	-039-	-040-	-041-	-042-	22.0	.001	22.0	.002	22.0	.015
0.0033	0.500 (12.70)	0.170 (4.32)	0.700 (17.78)	-043-	-044-	-045-	-046-	-047-	-048-	22.0	.001	22.0	.002	22.0	.018
0.0039	0.500 (12.70)	0.170 (4.32)	0.700 (17.78)	-049-	-050-	-051-	-052-	-053-	-054-	22.0	.001	22.0	.002	22.0	.021
0.0047	0.500 (12.70)	0.170 (4.32)	0.700 (17.78)	-055-	-056-	-057-	-058-	-059-	-060-	22.0	.001	22.0	.003	22.0	.026
0.005	0.500 (12.70)	0.170 (4.32)	0.700 (17.78)	-061-	-062-	-063-	-064-	-065-	-066-	22.0	.001	22.0	.003	22.0	.028
0.0056	0.500 (12.70)	0.170 (4.32)	0.700 (17.78)	-067-	-068-	-069-	-070-	-071-	-072-	22.0	.001	22.0	.003	22.0	.031
0.0068	0.500 (12.70)	0.170 (4.32)	0.700 (17.78)	-073-	-074-	-075-	-076-	-077-	-078-	22.0	.001	22.0	.004	22.0	.037
0.0082	0.500 (12.70)	0.170 (4.32)	0.700 (17.78)	-079-	-080-	-081-	-082-	-083-	-084-	22.0	.001	22.0	.005	22.0	.045
0.01	0.500 (12.70)	0.170 (4.32)	0.700 (17.78)	-085-	-086-	-087-	-088-	-089-	-090-	22.0	.001	22.0	.006	22.0	.055
0.012	0.500 (12.70)	0.170 (4.32)	0.700 (17.78)	-091-	-092-	-093-	-094-	-095-	-096-	22.0	.001	22.0	.007	22.0	.066
0.015	0.500 (12.70)	0.170 (4.32)	0.700 (17.78)	-097-	-098-	-099-	-100-	-101-	-102-	22.0	.001	22.0	.008	22.0	.082
0.018	0.500 (12.70)	0.170 (4.32)	0.700 (17.78)	-103-	-104-	-105-	-106-	-107-	-108-	22.0	.001	22.0	.010	22.0	.10
0.02	0.500 (12.70)	0.170 (4.32)	0.700 (17.78)	-109-	-110-	-111-	-112-	-113-	-114-	22.0	.001	22.0	.011	22.0	.11
0.022	0.500 (12.70)	0.170 (4.32)	0.700 (17.78)	-115-	-116-	-117-	-118-	-119-	-120-	22.0	.001	22.0	.012	22.0	.12
0.027	0.562 (14.27)	0.170 (4.32)	0.762 (19.35)	-121-	-122-	-123-	-124-	-125-	-126-	22.0	.001	22.0	.015	22.0	.15
0.033	0.562 (14.27)	0.170 (4.32)	0.762 (19.35)	-127-	-128-	-129-	-130-	-131-	-132-	22.0	.002	22.0	.018	22.0	.18
0.039	0.562 (14.27)	0.170 (4.32)	0.762 (19.35)	-133-	-134-	-135-	-136-	-137-	-138-	22.0	.002	22.0	.021	22.0	.22
0.047	0.562 (14.27)	0.170 (4.32)	0.762 (19.35)	-139-	-140-	-141-	-142-	-143-	-144-	22.0	.003	22.0	.026	22.0	.26
0.05	0.562 (14.27)	0.170 (4.32)	0.762 (19.35)	-145-	-146-	-147-	-148-	-149-	-150-	22.0	.003	22.0	.028	22.0	.28
0.056	0.562 (14.27)	0.170 (4.32)	0.762 (19.35)	-151-	-152-	-153-	-154-	-155-	-156-	22.0	.003	22.0	.031	22.0	.31
0.068	0.687 (17.45)	0.170 (4.32)	0.887 (22.53)	-157-	-158-	-159-	-160-	-161-	-162-	22.0	.004	22.0	.037	22.0	.37
0.082	0.687 (17.45)	0.170 (4.32)	0.887 (22.53)	-163-	-164-	-165-	-166-	-167-	-168-	22.0	.005	22.0	.045	22.0	.45
0.1	0.687 (17.45)	0.193 (4.90)	0.887 (22.53)	-169-	-170-	-171-	-172-	-173-	-174-	22.0	.006	22.0	.055	22.0	.55
0.12	0.687 (17.45)	0.193 (4.90)	0.887 (22.53)	-175-	-176-	-177-	-178-	-179-	-180-	22.0	.007	22.0	.066	22.0	.66
0.15	0.562 (14.27)	0.235 (5.97)	0.762 (19.35)	-181-	-182-	-183-	-184-	-185-	-186-	22.0	.008	22.0	.082	22.0	.83
0.18	0.687 (17.45)	0.235 (5.97)	0.887 (22.53)	-373-	-374-	-375-	-376-	-377-	-378-	22.0	.010	22.0	.100	22.0	1.00
0.20	0.687 (17.45)	0.235 (5.97)	0.887 (22.53)	-187-	-188-	-189-	-190-	-191-	-192-	22.0	.011	22.0	.110	20.0	1.00
0.22	0.687 (17.45)	0.235 (5.97)	0.887 (22.53)	-193-	-194-	-195-	-196-	-197-	-198-	22.0	.012	22.0	.120	18.5	1.02
0.27	0.687 (17.45)	0.235 (5.97)	0.887 (22.53)	-199-	-200-	-201-	-202-	-203-	-204-	22.0	.015	22.0	.150	17.0	1.15
0.33	0.687 (17.45)	0.235 (5.97)	0.887 (22.53)	-205-	-206-	-207-	-208-	-209-	-210-	22.0	.018	22.0	.180	16.0	1.32
0.39	0.687 (17.45)	0.235 (5.97)	0.887 (22.53)	-211-	-212-	-213-	-214-	-215-	-216-	22.0	.021	22.0	.21	15.0	1.46

See footnotes at end of table.

MIL-PRF-83421/1D

TABLE I. Electrical characteristics, dimensions, and dash numbers - Continued.

CRH01 AND CHR06 - 30 volts (DC rating)															
Capacitance value (nom) (in µf)	Dimensions ^{1/} (in inches with mm in parentheses)			Dash numbers ^{2/}						AC ratings (for sinusoidal operation from -65 to +100°C) ^{3/}					
	L ±.030 (0.76)	D +.020 (0.51) -.010 (0.25)	G, max	Capacitance tolerance value (in %)						0 to .4 kHz		At 4 kHz		At 40 kHz	
				±0.25	±0.5	±1.0	±2.0	±5.0	±10.0	Volts	Current (in A)	Volts	Current (in A)	Volts	Current (in A)
0.47	0.687 (17.45)	0.312 (7.92)	0.887 (22.53)	-217-	-218-	-219-	-220-	-221-	-222-	22.0	.026	22.0	.26	14.0	1.65
0.50	0.687 (17.45)	0.312 (7.92)	0.887 (22.53)	-223-	-224-	-225-	-226-	-227-	-228-	22.0	.028	22.0	.28	13.5	1.69
0.56	0.687 (17.45)	0.312 (7.92)	0.887 (22.53)	-229-	-230-	-231-	-232-	-233-	-234-	22.0	.031	22.0	.31	12.9	1.81
0.68	0.687 (17.45)	0.312 (7.92)	0.887 (22.53)	-235-	-236-	-237-	-238-	-239-	-240-	22.0	.037	22.0	.37	12.0	2.04
0.82	0.813 (20.65)	0.312 (7.92)	1.013 (25.73)	-241-	-242-	-243-	-244-	-245-	-246-	22.0	.045	22.0	.45	10.0	2.05
1.0	0.813 (20.65)	0.312 (7.92)	1.013 (25.73)	-247-	-248-	-249-	-250-	-251-	-252-	22.0	.055	22.0	.55	8.4	2.10
1.2	0.813 (20.65)	0.312 (7.92)	1.013 (25.73)	-253-	-254-	-255-	-256-	-257-	-258-	22.0	.066	22.0	.66	7.2	2.15
1.5	0.813 (20.65)	0.400 (10.16)	1.013 (25.73)	-259-	-260-	-261-	-262-	-263-	-264-	22.0	.082	22.0	.83	5.8	2.17
1.8	0.813 (20.65)	0.400 (10.16)	1.013 (25.73)	-265-	-266-	-267-	-268-	-269-	-270-	22.0	.099	22.0	.99	4.8	2.20
2.0	0.813 (20.65)	0.400 (10.16)	1.013 (25.73)	-271-	-272-	-273-	-274-	-275-	-276-	22.0	.110	22.0	1.10	4.4	2.20
2.2	0.813 (20.65)	0.400 (10.16)	1.013 (25.73)	-277-	-278-	-279-	-280-	-281-	-282-	22.0	.12	22.0	1.21	4.0	2.20
2.7	1.063 (27.00)	0.400 (10.16)	1.263 (32.08)	-385-	-386-	-387-	-388-	-389-	-390-	22.0	.15	22.0	1.49	3.3	2.20
3.0	1.063 (27.00)	0.400 (10.16)	1.263 (32.08)	-289-	-290-	-291-	-292-	-293-	-294-	22.0	.17	22.0	1.65	2.9	2.20
3.3	1.063 (27.00)	0.400 (10.16)	1.263 (32.08)	-295-	-296-	-297-	-298-	-299-	-300-	22.0	.18	22.0	1.82	2.7	2.20
3.9	1.375 (34.93)	0.400 (10.16)	1.575 (40.01)	-301-	-302-	-303-	-304-	-305-	-306-	22.0	.21	22.0	2.14	2.3	2.20
4.7	1.375 (34.93)	0.500 (12.70)	1.575 (40.01)	-313-	-314-	-315-	-316-	-317-	-318-	22.0	.26	18.7	2.20	1.9	2.20
5.0	1.375 (34.93)	0.500 (12.70)	1.575 (40.01)	-319-	-320-	-321-	-322-	-323-	-324-	22.0	.28	17.6	2.20	1.8	2.20
5.6	1.375 (34.93)	0.500 (12.70)	1.575 (40.01)	-325-	-326-	-327-	-328-	-329-	-330-	22.0	.31	15.7	2.20	1.6	2.20
6.8	1.375 (34.93)	0.562 (14.27)	1.575 (40.01)	-331-	-332-	-333-	-334-	-335-	-336-	22.0	.37	13.0	2.20	1.3	2.20
8.0	1.375 (34.93)	0.562 (14.27)	1.575 (40.01)	-337-	-338-	-339-	-340-	-341-	-342-	22.0	.44	11.0	2.20	1.1	2.20
8.2	1.375 (34.93)	0.562 (14.27)	1.575 (40.01)	-343-	-344-	-345-	-346-	-347-	-348-	22.0	.45	10.7	2.20	1.1	2.20
10.0	1.375 (34.93)	0.562 (14.27)	1.575 (40.01)	-349-	-350-	-351-	-352-	-353-	-354-	22.0	.55	8.8	2.20	.88	2.20
12.0	1.875 (47.63)	0.562 (14.27)	2.075 (52.71)	-379-	-380-	-381-	-382-	-383-	-384-	22.0	.66	7.3	2.20	.73	2.20
15.0	1.875 (47.63)	0.562 (14.27)	2.075 (52.71)	-355-	-356-	-357-	-358-	-359-	-360-	22.0	.83	5.9	2.20	.59	2.20
20.0	1.875 (47.63)	0.670 (17.02)	2.075 (52.71)	-361-	-362-	-363-	-364-	-365-	-366-	22.0	1.10	4.4	2.20	.44	2.20
22.0	1.875 (47.63)	0.670 (17.02)	2.075 (52.71)	-367-	-368-	-369-	-370-	-371-	-372-	22.0	1.21	4.0	2.20	.40	2.20
CRH02 AND CHR07 - 50 volts (DC rating)															
0.001	0.500 (12.70)	0.170 (4.32)	0.700 (17.78)	-001-	-002-	-003-	-004-	-005-	-006-	36.0	.001	36.0	.001	36.0	.009
0.0012	0.500 (12.70)	0.170 (4.32)	0.700 (17.78)	-007-	-008-	-009-	-010-	-011-	-012-	36.0	.001	36.0	.001	36.0	.011
0.0015	0.500 (12.70)	0.170 (4.32)	0.700 (17.78)	-013-	-014-	-015-	-016-	-017-	-018-	36.0	.001	36.0	.001	36.0	.013
0.0018	0.500 (12.70)	0.170 (4.32)	0.700 (17.78)	-019-	-020-	-021-	-022-	-023-	-024-	36.0	.001	36.0	.002	36.0	.016
0.002	0.500 (12.70)	0.170 (4.32)	0.700 (17.78)	-025-	-026-	-027-	-028-	-029-	-030-	36.0	.001	36.0	.002	36.0	.018
0.0022	0.500 (12.70)	0.170 (4.32)	0.700 (17.78)	-031-	-032-	-033-	-034-	-035-	-036-	36.0	.001	36.0	.002	36.0	.020
0.0027	0.500 (12.70)	0.170 (4.32)	0.700 (17.78)	-037-	-038-	-039-	-040-	-041-	-042-	36.0	.001	36.0	.002	36.0	.024
0.0033	0.500 (12.70)	0.170 (4.32)	0.700 (17.78)	-043-	-044-	-045-	-046-	-047-	-048-	36.0	.001	36.0	.003	36.0	.030
0.0039	0.500 (12.70)	0.170 (4.32)	0.700 (17.78)	-049-	-050-	-051-	-052-	-053-	-054-	36.0	.001	36.0	.004	36.0	.035

3

MIL-PRF-83421/1D

See footnotes at end of table.

TABLE I. Electrical characteristics, dimensions, and dash numbers - Continued.

CRH02 AND CHR07 - 50 volts (DC rating)															
Capacitance value (nom) (in μf)	Dimensions ^{1/} (in inches with mm in parentheses)			Dash numbers ^{2/}						AC ratings (for sinusoidal operation from -65 to +100°C) ^{3/}					
	L \pm .030 (0.76)	D +.020 (0.51) -.010 (0.25)	G, max	Capacitance tolerance value (in %)						0 to .4 kHz		At 4 kHz		At 40 kHz	
				\pm 0.25	\pm 0.5	\pm 1.0	\pm 2.0	\pm 5.0	\pm 10.0	Volts	Current (in A)	Volts	Current (in A)	Volts	Current (in A)
0.0047	0.500 (12.70)	0.170 (4.32)	0.700 (17.78)	-055-	-056-	-057-	-058-	-059-	-060-	36.0	.001	36.0	.004	36.0	.042
0.005	0.500 (12.70)	0.170 (4.32)	0.700 (17.78)	-061-	-062-	-063-	-064-	-065-	-066-	36.0	.001	36.0	.005	36.0	.045
0.0056	0.500 (12.70)	0.170 (4.32)	0.700 (17.78)	-067-	-068-	-069-	-070-	-071-	-072-	36.0	.001	36.0	.005	36.0	.050
0.0068	0.500 (12.70)	0.170 (4.32)	0.700 (17.78)	-073-	-074-	-075-	-076-	-077-	-078-	36.0	.001	36.0	.006	36.0	.061
0.0082	0.562 (14.27)	0.170 (4.32)	0.762 (19.35)	-079-	-080-	-081-	-082-	-083-	-084-	36.0	.001	36.0	.007	36.0	.074
0.01	0.562 (14.27)	0.170 (4.32)	0.762 (19.35)	-085-	-086-	-087-	-088-	-089-	-090-	36.0	.001	36.0	.009	36.0	.090
0.012	0.562 (14.27)	0.170 (4.32)	0.762 (19.35)	-091-	-092-	-093-	-094-	-095-	-096-	36.0	.001	36.0	.011	36.0	.11
0.015	0.562 (14.27)	0.170 (4.32)	0.762 (19.35)	-097-	-098-	-099-	-100-	-101-	-102-	36.0	.001	36.0	.013	36.0	.14
0.018	0.562 (14.27)	0.193 (4.90)	0.762 (19.35)	-103-	-104-	-105-	-106-	-107-	-108-	36.0	.002	36.0	.016	36.0	.16
0.02	0.562 (14.27)	0.193 (4.90)	0.762 (19.35)	-109-	-110-	-111-	-112-	-113-	-114-	36.0	.002	36.0	.018	36.0	.18
0.022	0.562 (14.27)	0.193 (4.90)	0.762 (19.35)	-115-	-116-	-117-	-118-	-119-	-120-	36.0	.002	36.0	.020	36.0	.20
0.027	0.562 (14.27)	0.193 (4.90)	0.762 (19.35)	-121-	-122-	-123-	-124-	-125-	-126-	36.0	.002	36.0	.024	36.0	.24
0.033	0.562 (14.27)	0.193 (4.90)	0.762 (19.35)	-127-	-128-	-129-	-130-	-131-	-132-	36.0	.003	36.0	.030	36.0	.30
0.039	0.687 (17.45)	0.170 (4.32)	0.887 (22.53)	-133-	-134-	-135-	-136-	-137-	-138-	36.0	.004	36.0	.035	36.0	.35
0.047	0.687 (17.45)	0.170 (4.32)	0.887 (22.53)	-139-	-140-	-141-	-142-	-143-	-144-	36.0	.004	36.0	.042	36.0	.42
0.05	0.687 (17.45)	0.170 (4.32)	0.887 (22.53)	-145-	-146-	-147-	-148-	-149-	-150-	36.0	.005	36.0	.045	36.0	.45
0.056	0.687 (17.45)	0.193 (4.90)	0.887 (22.53)	-151-	-152-	-153-	-154-	-155-	-156-	36.0	.005	36.0	.050	36.0	.50
0.068	0.687 (17.45)	0.193 (4.90)	0.887 (22.53)	-157-	-158-	-159-	-160-	-161-	-162-	36.0	.006	36.0	.061	34.0	.58
0.082	0.813 (20.65)	0.193 (4.90)	1.013 (25.73)	-163-	-164-	-165-	-166-	-167-	-168-	36.0	.007	36.0	.074	32.0	.66
0.1	0.813 (20.65)	0.193 (4.90)	1.013 (25.73)	-169-	-170-	-171-	-172-	-173-	-174-	36.0	.009	36.0	.090	30.0	.75
0.12	0.687 (17.45)	0.235 (5.97)	0.887 (22.53)	-175-	-176-	-177-	-178-	-179-	-180-	36.0	.011	36.0	.11	30.0	.90
0.15	0.687 (17.45)	0.235 (5.97)	0.887 (22.53)	-181-	-182-	-183-	-184-	-185-	-186-	36.0	.013	36.0	.14	26.0	.98
0.18	0.813 (20.65)	0.235 (5.97)	1.013 (25.73)	-187-	-188-	-189-	-190-	-191-	-192-	36.0	.016	36.0	.16	25.0	1.13
0.20	0.813 (20.65)	0.235 (5.97)	1.013 (25.73)	-193-	-194-	-195-	-196-	-197-	-198-	36.0	.018	36.0	.18	24.0	1.20
0.22	0.813 (20.65)	0.235 (5.97)	1.013 (25.73)	-199-	-200-	-201-	-202-	-203-	-204-	36.0	.020	36.0	.20	23.0	1.27
0.27	0.687 (17.45)	0.312 (7.92)	0.887 (22.53)	-205-	-206-	-207-	-208-	-209-	-210-	36.0	.024	36.0	.24	19.0	1.28
0.33	0.687 (17.45)	0.312 (7.92)	0.887 (22.53)	-211-	-212-	-213-	-214-	-215-	-216-	36.0	.030	36.0	.30	18.0	1.48
0.39	0.813 (20.65)	0.312 (7.92)	1.013 (25.73)	-217-	-218-	-219-	-220-	-221-	-222-	36.0	.035	36.0	.35	17.0	1.66
0.47	0.813 (20.65)	0.312 (7.92)	1.013 (25.73)	-223-	-224-	-225-	-226-	-227-	-228-	36.0	.042	36.0	.42	15.7	1.85
0.50	0.813 (20.65)	0.312 (7.92)	1.013 (25.73)	-229-	-230-	-231-	-232-	-233-	-234-	36.0	.045	36.0	.45	15.2	1.90
0.56	0.813 (20.65)	0.400 (10.16)	1.013 (25.73)	-235-	-236-	-237-	-238-	-239-	-240-	36.0	.050	36.0	.50	14.4	2.01
0.68	0.813 (20.65)	0.400 (10.16)	1.013 (25.73)	-241-	-242-	-243-	-244-	-245-	-246-	36.0	.061	36.0	.61	14.0	2.38
0.82	1.063 (27.00)	0.400 (10.16)	1.263 (32.08)	-247-	-248-	-249-	-250-	-251-	-252-	36.0	.074	36.0	.74	12.0	2.46
1.0	1.063 (27.00)	0.400 (10.16)	1.263 (32.08)	-253-	-254-	-255-	-256-	-257-	-258-	36.0	.090	36.0	.90	10.0	2.50
1.2	1.063 (27.00)	0.400 (10.16)	1.263 (32.08)	-259-	-260-	-261-	-262-	-263-	-264-	36.0	.11	36.0	1.08	9.1	2.73
1.5	1.063 (27.00)	0.400 (10.16)	1.263 (32.08)	-265-	-266-	-267-	-268-	-269-	-270-	36.0	.14	36.0	1.35	7.7	2.90
1.8	1.063 (27.00)	0.400 (10.16)	1.263 (32.08)	-271-	-272-	-273-	-274-	-275-	-276-	36.0	.16	36.0	1.62	6.6	3.00

See footnotes at end of table.

TABLE I. Electrical characteristics, dimensions, and dash numbers - Continued.

CRH02 AND CHR07 - 50 volts (DC rating)															
Capacitance value (nom) (in µf)	Dimensions ^{1/} (in inches with mm in parentheses)			Dash numbers ^{2/}						AC ratings (for sinusoidal operation from -65 to +100°C) ^{3/}					
	L ±.030 (0.76)	D +.020 (0.51) -.010 (0.25)	G, max	Capacitance tolerance value (in %)						0 to .4 kHz		At 4 kHz		At 40 kHz	
				±0.25	±0.5	±1.0	±2.0	±5.0	±10.0	Volts	Current (in A)	Volts	Current (in A)	Volts	Current (in A)
2.0	1.125 (28.58)	0.500 (12.70)	1.325 (33.66)	-277-	-278-	-279-	-280-	-281-	-282-	36.0	.18	36.0	1.80	6.2	3.10
2.2	1.125 (28.58)	0.500 (12.70)	1.325 (33.66)	-283-	-284-	-285-	-286-	-287-	-288-	36.0	.20	36.0	1.98	5.8	3.20
2.7	1.375 (34.93)	0.500 (12.70)	1.575 (40.01)	-289-	-290-	-291-	-292-	-293-	-294-	36.0	.24	36.0	2.43	5.0	3.34
3.0	1.375 (34.93)	0.500 (12.70)	1.575 (40.01)	-295-	-296-	-297-	-298-	-299-	-300-	36.0	.27	36.0	2.70	4.5	3.40
3.3	1.375 (34.93)	0.500 (12.70)	1.575 (40.01)	-301-	-302-	-303-	-304-	-305-	-306-	36.0	.30	36.0	2.97	4.2	3.50
3.9	1.375 (34.93)	0.562 (14.27)	1.575 (40.01)	-307-	-308-	-309-	-310-	-311-	-312-	36.0	.35	36.0	3.51	3.7	3.60
4.7	1.375 (34.93)	0.670 (17.02)	1.575 (40.01)	-319-	-320-	-321-	-322-	-323-	-324-	36.0	.42	31.0	3.60	3.1	3.60
5.0	1.375 (34.93)	0.670 (17.02)	1.575 (40.01)	-325-	-326-	-327-	-328-	-329-	-330-	36.0	.45	29.0	3.60	2.9	3.60
5.6	1.375 (34.93)	0.670 (17.02)	1.575 (40.01)	-331-	-332-	-333-	-334-	-335-	-336-	36.0	.50	26.0	3.60	2.6	3.60
6.8	1.875 (47.63)	0.670 (17.02)	2.075 (52.71)	-337-	-338-	-330-	-340-	-341-	-342-	36.0	.61	21.2	3.60	2.1	3.60
8.0	1.875 (47.63)	0.670 (17.02)	2.075 (52.71)	-343-	-344-	-345-	-346-	-347-	-348-	36.0	.72	18.0	3.60	1.8	3.60
8.2	1.875 (47.63)	0.670 (17.02)	2.075 (52.71)	-349-	-350-	-351-	-352-	-353-	-354-	36.0	.74	17.6	3.60	1.8	3.60
10.0	1.875 (47.63)	0.670 (17.02)	2.075 (52.71)	-355-	-356-	-357-	-358-	-359-	-360-	36.0	.90	14.4	3.60	1.4	3.60
CRH03 AND CRH08 - 100 VOLTS (DC RATING)															
0.001	0.500 (12.70)	0.170 (4.32)	0.700 (17.78)	-001-	-002-	-003-	-004-	-005-	-006-	60.0	.001	60.0	.002	60.0	.015
0.0012	0.500 (12.70)	0.170 (4.32)	0.700 (17.78)	-007-	-008-	-009-	-010-	-011-	-012-	60.0	.001	60.0	.002	60.0	.018
0.0015	0.500 (12.70)	0.170 (4.32)	0.700 (17.78)	-013-	-014-	-015-	-016-	-017-	-018-	60.0	.001	60.0	.002	60.0	.022
0.0018	0.500 (12.70)	0.170 (4.32)	0.700 (17.78)	-019-	-020-	-021-	-022-	-023-	-024-	60.0	.001	60.0	.003	60.0	.027
0.002	0.500 (12.70)	0.170 (4.32)	0.700 (17.78)	-025-	-026-	-027-	-028-	-029-	-030-	60.0	.001	60.0	.003	60.0	.030
0.0022	0.500 (12.70)	0.170 (4.32)	0.700 (17.78)	-031-	-032-	-033-	-034-	-035-	-036-	60.0	.001	60.0	.003	60.0	.033
0.0027	0.500 (12.70)	0.170 (4.32)	0.700 (17.78)	-037-	-038-	-039-	-040-	-041-	-042-	60.0	.001	60.0	.004	60.0	.041
0.0033	0.500 (12.70)	0.170 (4.32)	0.700 (17.78)	-043-	-044-	-045-	-046-	-047-	-048-	60.0	.001	60.0	.005	60.0	.050
0.0039	0.500 (12.70)	0.170 (4.32)	0.700 (17.78)	-049-	-050-	-051-	-052-	-053-	-054-	60.0	.001	60.0	.006	60.0	.058
0.0047	0.500 (12.70)	0.170 (4.32)	0.700 (17.78)	-055-	-056-	-057-	-058-	-059-	-060-	60.0	.001	60.0	.007	60.0	.071
0.005	0.500 (12.70)	0.170 (4.32)	0.700 (17.78)	-061-	-062-	-063-	-064-	-065-	-066-	60.0	.001	60.0	.008	60.0	.075
0.0056	0.500 (12.70)	0.170 (4.32)	0.700 (17.78)	-067-	-068-	-069-	-070-	-071-	-072-	60.0	.001	60.0	.008	60.0	.084
0.0068	0.562 (14.27)	0.170 (4.32)	0.762 (19.35)	-073-	-074-	-075-	-076-	-077-	-078-	60.0	.001	60.0	.010	60.0	.10
0.0082	0.562 (14.27)	0.170 (4.32)	0.762 (19.35)	-079-	-080-	-081-	-082-	-083-	-084-	60.0	.001	60.0	.012	60.0	.12
0.01	0.687 (17.45)	0.170 (4.32)	0.887 (22.53)	-085-	-086-	-087-	-088-	-089-	-090-	60.0	.002	60.0	.015	60.0	.15
0.012	0.687 (17.45)	0.170 (4.32)	0.887 (22.53)	-091-	-092-	-093-	-094-	-095-	-096-	60.0	.002	60.0	.018	59.0	.18
0.015	0.687 (17.45)	0.170 (4.32)	0.887 (22.53)	-097-	-098-	-099-	-100-	-101-	-102-	60.0	.002	60.0	.022	58.0	.22
0.018	0.687 (17.45)	0.193 (4.90)	0.887 (22.53)	-103-	-104-	-105-	-106-	-107-	-108-	60.0	.003	60.0	.027	57.0	.26
0.02	0.687 (17.45)	0.193 (4.90)	0.887 (22.53)	-109-	-110-	-111-	-112-	-113-	-114-	60.0	.003	60.0	.030	55.0	.28
0.022	0.687 (17.45)	0.193 (4.90)	0.887 (22.53)	-115-	-116-	-117-	-118-	-119-	-120-	60.0	.003	60.0	.033	53.0	.29
0.027	0.687 (17.45)	0.193 (4.90)	0.887 (22.53)	-121-	-122-	-123-	-124-	-125-	-126-	60.0	.004	60.0	.041	51.0	.34

MIL-PRF-83421/1D

See footnotes at end of table.

TABLE I. Electrical characteristics, dimensions, and dash numbers - Continued.

CRH03 AND CRH08 - 100 VOLTS (DC RATING)															
Capacitance value (nom) (in μf)	Dimensions ^{1/} (in inches with mm in parentheses)			Dash numbers ^{2/}						AC ratings (for sinusoidal operation from -65 to +100°C) ^{3/}					
	L \pm .030 (0.76)	D +.020 (0.51) -.010 (0.25)	G, max	Capacitance tolerance value (in %)						0 to .4 kHz		At 4 kHz		At 40 kHz	
				\pm 0.25	\pm 0.5	\pm 1.0	\pm 2.0	\pm 5.0	\pm 10.0	Volts	Current (in A)	Volts	Current (in A)	Volts	Current (in A)
0.033	0.687 (17.45)	0.193 (4.90)	0.887 (22.53)	-127-	-128-	-129-	-130-	-131-	-132-	60.0	.005	60.0	.050	50.0	.41
0.039	0.687 (17.45)	0.235 (5.97)	0.887 (22.53)	-133-	-134-	-135-	-136-	-137-	-138-	60.0	.006	60.0	.059	48.0	.47
0.047	0.687 (17.45)	0.235 (5.97)	0.887 (22.53)	-139-	-140-	-141-	-142-	-143-	-144-	60.0	.007	60.0	.070	47.0	.55
0.050	0.687 (17.45)	0.235 (5.97)	0.887 (22.53)	-145-	-146-	-147-	-148-	-149-	-150-	60.0	.008	60.0	.075	46.0	.58
0.056	0.687 (17.45)	0.235 (5.97)	0.887 (22.53)	-151-	-152-	-153-	-154-	-155-	-156-	60.0	.008	60.0	.084	46.0	.64
0.068	0.813 (20.65)	0.235 (5.97)	1.013 (25.73)	-157-	-158-	-159-	-160-	-161-	-162-	60.0	.010	60.0	.10	42.0	.71
0.082	0.687 (17.45)	0.312 (7.92)	0.887 (22.53)	-163-	-164-	-165-	-166-	-167-	-168-	60.0	.012	60.0	.12	38.0	.78
0.10	0.687 (17.45)	0.312 (7.92)	0.887 (22.53)	-169-	-170-	-171-	-172-	-173-	-174-	60.0	.015	60.0	.15	36.0	.90
0.12	0.687 (17.45)	0.312 (7.92)	0.887 (22.53)	-175-	-176-	-177-	-178-	-179-	-180-	60.0	.018	60.0	.18	35.0	1.05
0.15	0.813 (20.65)	0.312 (7.92)	1.013 (25.73)	-181-	-182-	-183-	-184-	-185-	-186-	60.0	.022	60.0	.23	33.0	1.24
0.18	0.813 (20.65)	0.312 (7.92)	1.013 (25.73)	-187-	-188-	-189-	-190-	-191-	-192-	60.0	.027	60.0	.27	31.0	1.40
0.20	0.813 (20.65)	0.312 (7.92)	1.013 (25.73)	-193-	-194-	-195-	-196-	-197-	-198-	60.0	.030	60.0	.30	30.0	1.50
0.22	0.813 (20.65)	0.312 (7.92)	1.013 (25.73)	-199-	-200-	-201-	-202-	-203-	-204-	60.0	.033	60.0	.33	27.0	1.50
0.27	1.063 (27.00)	0.312 (7.92)	1.263 (32.08)	-205-	-206-	-207-	-208-	-209-	-210-	60.0	.041	60.0	.41	24.0	1.62
0.33	1.063 (27.00)	0.312 (7.92)	1.263 (32.08)	-211-	-212-	-213-	-214-	-215-	-216-	60.0	.050	60.0	.50	23.0	1.90
0.39	1.063 (27.00)	0.400 (10.16)	1.263 (32.08)	-217-	-218-	-219-	-220-	-221-	-222-	60.0	.058	60.0	.59	22.0	2.15
0.47	1.063 (27.00)	0.400 (10.16)	1.263 (32.08)	-223-	-224-	-225-	-226-	-227-	-228-	60.0	.071	60.0	.71	21.0	2.47
0.50	1.063 (27.00)	0.400 (10.16)	1.263 (32.08)	-229-	-230-	-231-	-232-	-233-	-234-	60.0	.075	60.0	.75	20.0	2.50
0.56	1.063 (27.00)	0.400 (10.16)	1.263 (32.08)	-235-	-236-	-237-	-238-	-239-	-240-	60.0	.084	60.0	.84	19.0	2.64
0.68	1.125 (28.58)	0.500 (12.70)	1.325 (33.66)	-241-	-242-	-243-	-244-	-245-	-246-	60.0	.10	60.0	1.02	16.0	2.72
0.82	1.125 (28.58)	0.500 (12.70)	1.325 (33.66)	-247-	-248-	-249-	-250-	-251-	-252-	60.0	.12	60.0	1.23	14.0	2.87
1.0	1.125 (28.58)	0.562 (14.27)	1.325 (33.66)	-253-	-254-	-255-	-256-	-257-	-258-	60.0	.15	60.0	1.50	12.0	3.00
1.2	1.125 (28.58)	0.562 (14.27)	1.325 (33.66)	-259-	-260-	-261-	-262-	-263-	-264-	60.0	.18	60.0	1.80	11.0	3.25
1.5	1.375 (34.93)	0.562 (14.27)	1.575 (40.01)	-265-	-266-	-267-	-268-	-269-	-270-	60.0	.23	60.0	2.26	10.0	3.75
2.0	1.375 (34.93)	0.670 (17.02)	1.575 (40.01)	-271-	-272-	-273-	-274-	-275-	-276-	60.0	.30	60.0	3.00	8.1	4.10
2.2	1.375 (34.93)	0.670 (17.02)	1.575 (40.01)	-277-	-278-	-279-	-280-	-281-	-282-	60.0	.33	60.0	3.31	7.5	4.12
2.7	1.875 (47.63)	0.670 (17.02)	2.075 (40.01)	-283-	-284-	-285-	-286-	-287-	-288-	60.0	.41	60.0	4.05	6.5	4.40
3.0	1.875 (47.63)	0.670 (17.02)	2.075 (52.71)	-289-	-290-	-291-	-292-	-293-	-294-	60.0	.45	60.0	4.51	6.0	4.51
3.3	1.875 (47.63)	0.670 (17.02)	2.075 (52.71)	-295-	-296-	-297-	-298-	-299-	-300-	60.0	.50	55.0	4.73	5.5	4.55
3.9	1.875 (47.63)	0.750 (19.05)	2.075 (52.71)	-301-	-302-	-303-	-304-	-305-	-306-	60.0	.59	49.0	4.90	5.0	4.90
4.7	1.875 (47.63)	0.750 (19.05)	2.075 (52.71)	-313-	-314-	-315-	-316-	-317-	-318-	60.0	.71	43.0	5.00	4.3	5.00
5.0	1.875 (47.63)	0.750 (19.05)	2.075 (52.71)	-319-	-320-	-321-	-322-	-323-	-324-	60.0	.75	40.0	5.00	4.0	5.00
5.6	1.875 (47.63)	0.750 (19.05)	2.075 (52.71)	-325-	-326-	-327-	-328-	-329-	-330-	60.0	.84	36.0	5.00	3.6	5.00
6.8	2.375 (60.33)	1.000 (25.4)	2.575 (65.41)	-331-	-332-	-333-	-334-	-335-	-336-	60.0	1.02	29.0	5.00	3.0	5.00
8.0	2.375 (60.33)	1.000 (25.4)	2.575 (65.41)	-337-	-338-	-339-	-340-	-341-	-342-	60.0	1.20	25.0	5.00	2.5	5.00
8.2	2.375 (60.33)	1.000 (25.4)	2.575 (65.41)	-343-	-344-	-345-	-346-	-347-	-348-	60.0	1.23	24.4	5.00	2.4	5.00
10.0	2.375 (60.33)	1.000 (25.4)	2.575 (65.41)	-349-	-350-	-351-	-352-	-353-	-354-	60.0	1.50	20.0	5.00	2.0	5.00

MIL-PRF-83421/1D

See footnotes at end of table.

TABLE I. Electrical characteristics, dimensions, and dash numbers - Continued.

CRH04 AND CRH09 - 200 VOLTS (DC RATING)															
Capacitance value (nom) (in µf)	Dimensions ^{1/} (in inches with mm in parentheses)			Dash numbers ^{2/}						AC ratings (for sinusoidal operation from -65 to +100°C) ^{3/}					
	L ±.030 (0.76)	D +.020 (0.51) -.010 (0.25)	G, max	Capacitance tolerance value (in %)						0 to .4 kHz		At 4 kHz		At 40 kHz	
				±0.25	±0.5	±1.0	±2.0	±5.0	±10.0	Volts	Current (in A)	Volts	Current (in A)	Volts	Current (in A)
0.001	0.562 (14.27)	0.170 (4.32)	0.762 (19.35)	-001-	-002-	-003-	-004-	-005-	-006-	120.0	.001	120.0	.003	80.0	.020
0.0012	0.562 (14.27)	0.170 (4.32)	0.762 (19.35)	-007-	-008-	-009-	-010-	-011-	-012-	120.0	.001	120.0	.004	80.0	.024
0.0015	0.562 (14.27)	0.170 (4.32)	0.762 (19.35)	-013-	-014-	-015-	-016-	-017-	-018-	120.0	.001	120.0	.004	80.0	.030
0.0018	0.562 (14.27)	0.170 (4.32)	0.762 (19.35)	-019-	-020-	-021-	-022-	-023-	-024-	120.0	.005	120.0	.005	80.0	.036
0.002	0.562 (14.27)	0.170 (4.32)	0.762 (19.35)	-025-	-026-	-027-	-028-	-029-	-030-	120.0	.001	120.0	.006	80.0	.040
0.0022	0.562 (14.27)	0.170 (4.32)	0.762 (19.35)	-031-	-032-	-033-	-034-	-035-	-036-	120.0	.001	120.0	.007	80.0	.044
0.0027	0.562 (14.27)	0.170 (4.32)	0.762 (19.35)	-037-	-038-	-039-	-040-	-041-	-042-	120.0	.001	120.0	.008	80.0	.054
0.0033	0.562 (14.27)	0.170 (4.32)	0.762 (19.35)	-043-	-044-	-045-	-046-	-047-	-048-	120.0	.001	120.0	.010	80.0	.066
0.0039	0.562 (14.27)	0.170 (4.32)	0.762 (19.35)	-049-	-050-	-051-	-052-	-053-	-054-	120.0	.001	120.0	.012	80.0	.078
0.0047	0.562 (14.27)	0.170 (4.32)	0.762 (19.35)	-055-	-056-	-057-	-058-	-059-	-060-	120.0	.001	120.0	.014	80.0	.094
0.005	0.562 (14.27)	0.170 (4.32)	0.762 (19.35)	-061-	-062-	-063-	-064-	-065-	-066-	120.0	.002	120.0	.015	80.0	.10
0.0056	0.562 (14.27)	0.170 (4.32)	0.762 (19.35)	-067-	-068-	-069-	-070-	-071-	-072-	120.0	.002	120.0	.017	80.0	.11
0.0068	0.562 (14.27)	0.170 (4.32)	0.762 (19.35)	-073-	-074-	-075-	-076-	-077-	-078-	120.0	.002	120.0	.020	80.0	.14
0.0082	0.562 (14.27)	0.193 (4.90)	0.762 (19.35)	-079-	-080-	-081-	-082-	-083-	-084-	120.0	.002	120.0	.025	80.0	.16
0.01	0.562 (14.27)	0.193 (4.90)	0.762 (19.35)	-085-	-086-	-087-	-088-	-089-	-090-	120.0	.003	120.0	.030	80.0	.20
0.012	0.562 (14.27)	0.193 (4.90)	0.762 (19.35)	-091-	-092-	-093-	-094-	-095-	-096-	120.0	.004	120.0	.036	78.0	.23
0.015	0.562 (14.27)	0.235 (5.97)	0.762 (19.35)	-097-	-098-	-099-	-100-	-101-	-102-	120.0	.004	120.0	.045	76.0	.29
0.018	0.687 (17.45)	0.235 (5.97)	0.887 (22.53)	-103-	-104-	-105-	-106-	-107-	-108-	120.0	.005	120.0	.054	74.0	.33
0.02	0.687 (17.45)	0.235 (5.97)	0.887 (22.53)	-109-	-110-	-111-	-112-	-113-	-114-	120.0	.006	120.0	.060	71.0	.36
0.022	0.687 (17.45)	0.235 (5.97)	0.887 (22.53)	-115-	-116-	-117-	-118-	-119-	-120-	120.0	.007	120.0	.066	68.0	.37
0.027	0.687 (17.45)	0.312 (7.92)	0.887 (22.53)	-121-	-122-	-123-	-124-	-125-	-126-	120.0	.008	120.0	.081	65.0	.44
0.033	0.687 (17.45)	0.312 (7.92)	0.887 (22.53)	-127-	-128-	-129-	-130-	-131-	-132-	120.0	.010	120.0	.099	62.0	.51
0.039	0.687 (17.45)	0.312 (7.92)	0.887 (22.53)	-133-	-134-	-135-	-136-	-137-	-138-	120.0	.012	120.0	.12	60.0	.59
0.047	0.687 (17.45)	0.312 (7.92)	0.887 (22.53)	-139-	-140-	-141-	-142-	-143-	-144-	120.0	.014	120.0	.14	57.0	.67
0.05	0.687 (17.45)	0.312 (7.92)	0.887 (22.53)	-145-	-146-	-147-	-148-	-149-	-150-	120.0	.015	120.0	.15	56.0	.70
0.056	0.813 (20.65)	0.312 (7.92)	1.013 (20.65)	-151-	-152-	-153-	-154-	-155-	-156-	120.0	.017	120.0	.17	56.0	.78
0.068	0.813 (20.65)	0.312 (7.92)	1.013 (20.65)	-157-	-158-	-159-	-160-	-161-	-162-	120.0	.020	120.0	.20	50.0	.85
0.082	0.813 (20.65)	0.312 (7.92)	1.013 (20.65)	-163-	-164-	-165-	-166-	-167-	-168-	120.0	.025	120.0	.25	44.0	.90
0.1	0.813 (20.65)	0.312 (7.92)	1.013 (20.65)	-169-	-170-	-171-	-172-	-173-	-174-	120.0	.030	120.0	.30	42.0	1.10
0.12	0.813 (20.65)	0.312 (7.92)	1.013 (20.65)	-175-	-176-	-177-	-178-	-179-	-180-	120.0	.036	120.0	.36	40.0	1.20
0.15	1.063 (27.00)	0.400 (10.16)	1.263 (32.08)	-181-	-182-	-183-	-184-	-185-	-186-	120.0	.045	120.0	.45	36.0	1.34
0.18	1.375 (34.93)	0.400 (10.16)	1.575 (40.01)	-187-	-188-	-189-	-190-	-191-	-192-	120.0	.054	120.0	.54	34.0	1.54
0.20	1.375 (34.93)	0.400 (10.16)	1.575 (40.01)	-193-	-194-	-195-	-196-	-197-	-198-	120.0	.060	120.0	.60	33.0	1.65
0.22	1.375 (34.93)	0.400 (10.16)	1.575 (40.01)	-199-	-200-	-201-	-202-	-203-	-204-	120.0	.066	120.0	.66	32.0	1.76
0.27	1.375 (34.93)	0.500 (12.70)	1.575 (40.01)	-205-	-206-	-207-	-208-	-209-	-210-	120.0	.081	120.0	.81	29.0	1.96
0.33	1.375 (34.93)	0.500 (12.70)	1.575 (40.01)	-211-	-212-	-213-	-214-	-215-	-216-	120.0	.099	120.0	.99	28.0	2.31

MIL-PRF-83421/1D

7

See footnotes at end of table.

TABLE I. Electrical characteristics, dimensions, and dash numbers - Continued.

CRH04 AND CRH09 - 200 VOLTS (DC RATING)															
Capacitance value (nom) (in µf)	Dimensions ^{1/} (in inches with mm in parentheses)			Dash numbers ^{2/}						AC ratings (for sinusoidal operation from -65 to +100°C) ^{3/}					
	L ±.030 (0.76)	D +.020 (0.51) -.010 (0.25)	G, max	Capacitance tolerance value (in %)						0 to .4 kHz		At 4 kHz		At 40 kHz	
				±0.25	±0.5	±1.0	±2.0	±5.0	±10.0	Volts	Current (in A)	Volts	Current (in A)	Volts	Current (in A)
0.39	1.375 (34.93)	0.500 (12.70)	1.575 (40.01)	-217-	-218-	-219-	-220-	-221-	-222-	120.0	.12	120.0	1.17	27.0	2.63
0.47	1.375 (34.93)	0.500 (12.70)	1.575 (40.01)	-223-	-224-	-225-	-226-	-227-	-228-	120.0	.14	120.0	1.41	26.0	3.06
0.50	1.375 (34.93)	0.500 (12.70)	1.575 (40.01)	-229-	-230-	-231-	-232-	-233-	-234-	120.0	.15	120.0	1.50	25.0	3.13
0.56	1.375 (34.93)	0.500 (12.70)	1.575 (40.01)	-235-	-236-	-237-	-238-	-239-	-240-	120.0	.17	120.0	1.61	23.0	3.17
0.68	1.375 (34.93)	0.562 (14.27)	1.575 (40.01)	-241-	-242-	-243-	-244-	-245-	-246-	120.0	.20	120.0	1.87	20.0	3.40
0.82	1.875 (47.63)	0.562 (14.27)	2.075 (52.71)	-247-	-248-	-249-	-250-	-251-	-252-	120.0	.25	120.0	2.05	18.0	3.70
1.0	1.875 (47.63)	0.562 (14.27)	2.075 (52.71)	-253-	-254-	-255-	-256-	-257-	-258-	120.0	.30	120.0	2.25	15.0	3.75
1.2	1.875 (47.63)	0.562 (14.27)	2.075 (52.71)	-259-	-260-	-261-	-262-	-263-	-264-	120.0	.36	120.0	2.61	13.5	4.05
1.5	1.875 (47.63)	0.670 (17.02)	2.075 (52.71)	-265-	-266-	-267-	-268-	-269-	-270-	120.0	.45	120.0	3.20	12.0	4.50
1.8	1.875 (47.63)	0.750 (19.05)	2.075 (52.71)	-271-	-272-	-273-	-274-	-275-	-276-	120.0	.54	110.0	3.74	11.0	5.00
2.0	1.875 (47.63)	0.750 (19.05)	2.075 (52.71)	-277-	-278-	-279-	-280-	-281-	-282-	120.0	.60	100.0	4.05	10.0	5.00
2.2	1.875 (47.63)	0.750 (19.05)	2.075 (52.71)	-283-	-284-	-285-	-286-	-287-	-288-	120.0	.66	90.5	4.20	9.1	5.00
2.5	1.875 (47.63)	0.750 (19.05)	2.075 (52.71)	-289-	-290-	-291-	-292-	-293-	-294-	120.0	.75	80.0	4.31	8.0	5.00
2.7	1.875 (47.63)	0.750 (19.05)	2.075 (52.71)	-295-	-296-	-297-	-298-	-299-	-300-	120.0	.81	77.0	4.60	7.7	5.20
3.0	1.875 (47.63)	1.000 (25.40)	2.075 (52.71)	-301-	-302-	-303-	-304-	-305-	-306-	120.0	.90	70.0	5.04	7.0	5.27
3.3	1.875 (47.63)	1.000 (25.40)	2.075 (52.71)	-307-	-308-	-309-	-310-	-311-	-312-	120.0	.99	65.0	5.21	6.5	5.36
3.9	2.375 (60.33)	1.000 (25.40)	2.575 (65.41)	-313-	-314-	-315-	-316-	-317-	-318-	120.0	1.20	55.0	5.39	5.5	5.40
CRH05 AND CRH00 - 400 VOLTS (DC RATING)															
0.001	0.562 (14.27)	0.193 (4.90)	0.762 (19.35)	-001-	-002-	-003-	-004-	-005-	-006-	240.0	.001	240.0	.006	100.0	.025
0.0012	0.562 (14.27)	0.193 (4.90)	0.762 (19.35)	-007-	-008-	-009-	-010-	-011-	-012-	240.0	.001	240.0	.007	100.0	.030
0.0015	0.562 (14.27)	0.193 (4.90)	0.762 (19.35)	-013-	-014-	-015-	-016-	-017-	-018-	240.0	.001	240.0	.009	100.0	.037
0.0018	0.562 (14.27)	0.193 (4.90)	0.762 (19.35)	-019-	-020-	-021-	-022-	-023-	-024-	240.0	.001	240.0	.011	100.0	.045
0.002	0.562 (14.27)	0.193 (4.90)	0.762 (19.35)	-025-	-026-	-027-	-028-	-029-	-030-	240.0	.001	240.0	.012	100.0	.050
0.0022	0.562 (14.27)	0.193 (4.90)	0.762 (19.35)	-031-	-032-	-033-	-034-	-035-	-036-	240.0	.001	240.0	.013	100.0	.055
0.0027	0.562 (14.27)	0.235 (5.97)	0.762 (19.35)	-037-	-038-	-039-	-040-	-041-	-042-	240.0	.002	240.0	.016	100.0	.068
0.0033	0.562 (14.27)	0.235 (5.97)	0.762 (19.35)	-043-	-044-	-045-	-046-	-047-	-048-	240.0	.002	240.0	.020	100.0	.083
0.0039	0.562 (14.27)	0.235 (5.97)	0.762 (19.35)	-049-	-050-	-051-	-052-	-053-	-054-	240.0	.002	240.0	.023	100.0	.097
0.0047	0.562 (14.27)	0.235 (5.97)	0.762 (19.35)	-055-	-056-	-057-	-058-	-059-	-060-	240.0	.003	240.0	.028	100.0	.12
0.005	0.562 (14.27)	0.235 (5.97)	0.762 (19.35)	-061-	-062-	-063-	-064-	-065-	-066-	240.0	.003	240.0	.030	100.0	.13
0.0056	0.562 (14.27)	0.235 (5.97)	0.762 (19.35)	-067-	-068-	-069-	-070-	-071-	-072-	240.0	.003	240.0	.034	100.0	.14
0.0068	0.687 (17.45)	0.235 (5.97)	0.887 (22.53)	-073-	-074-	-075-	-076-	-077-	-078-	240.0	.004	240.0	.041	100.0	.17
0.0082	0.687 (17.45)	0.235 (5.97)	0.887 (22.53)	-079-	-080-	-081-	-082-	-083-	-084-	240.0	.005	240.0	.049	100.0	.21
0.01	0.687 (17.45)	0.235 (5.97)	0.887 (22.53)	-085-	-086-	-087-	-088-	-089-	-090-	240.0	.006	240.0	.060	100.0	.25
0.012	0.687 (17.45)	0.235 (5.97)	0.887 (22.53)	-091-	-092-	-093-	-094-	-095-	-096-	240.0	.007	240.0	.072	100.0	.30
0.015	0.813 (20.65)	0.235 (5.97)	1.013 (25.73)	-097-	-098-	-099-	-100-	-101-	-102-	240.0	.009	240.0	.090	94.0	.35
0.018	0.813 (20.65)	0.312 (7.92)	1.013 (25.73)	-103-	-104-	-105-	-106-	-107-	-108-	240.0	.011	240.0	.11	90.0	.41

See footnotes at end of table.

MIL-PRF-83421/1D

TABLE I. Electrical characteristics, dimensions, and dash numbers - Continued.

CRH05 AND CRH00 - 400 VOLTS (DC RATING)															
Capacitance value (nom) (in µf)	Dimensions ^{1/} (in inches with mm in parentheses)			Dash numbers ^{2/}						AC ratings (for sinusoidal operation from -65 to +100°C) ^{3/}					
	L ±.030 (0.76)	D +.020 (0.51) -.010 (0.25)	G, max	Capacitance tolerance value (in %)						0 to .4 kHz		At 4 kHz		At 40 kHz	
				±0.25	±0.5	±1.0	±2.0	±5.0	±10.0	Volts	Current (in A)	Volts	Current (in A)	Volts	Current (in A)
0.02	0.813 (20.65)	0.312 (7.92)	1.013 (25.73)	-271-	-272-	-273-	-274-	-275-	-276-	240.0	.012	240.0	.12	88.0	.44
0.022	0.813 (20.65)	0.312 (7.92)	1.013 (25.73)	-109-	-110-	-111-	-112-	-113-	-114-	240.0	.013	240.0	.13	85.0	.47
0.027	0.813 (20.65)	0.312 (7.92)	1.013 (25.73)	-115-	-116-	-117-	-118-	-119-	-120-	240.0	.016	240.0	.16	81.0	.55
0.033	0.813 (20.65)	0.312 (7.92)	1.013 (25.73)	-121-	-122-	-123-	-124-	-125-	-126-	240.0	.020	240.0	.20	78.0	.65
0.039	0.813 (20.65)	0.312 (7.92)	1.013 (25.73)	-127-	-128-	-129-	-130-	-131-	-132-	240.0	.023	240.0	.23	75.0	.73
0.047	0.813 (20.65)	0.400 (10.16)	1.013 (25.73)	-133-	-134-	-135-	-136-	-137-	-138-	240.0	.028	240.0	.28	71.0	.83
0.05	0.813 (20.65)	0.400 (10.16)	1.013 (25.73)	-139-	-140-	-141-	-142-	-143-	-144-	240.0	.030	240.0	.30	70.0	.88
0.056	0.813 (20.65)	0.400 (10.16)	1.013 (25.73)	-145-	-146-	-147-	-148-	-149-	-150-	240.0	.034	240.0	.34	67.5	.95
0.068	0.813 (20.65)	0.400 (10.16)	1.013 (25.73)	-151-	-152-	-153-	-154-	-155-	-156-	240.0	.041	240.0	.41	60.0	1.02
0.082	1.063 (27.00)	0.400 (10.16)	1.263 (32.08)	-157-	-158-	-159-	-160-	-161-	-162-	240.0	.049	240.0	.49	50.0	1.03
0.10	1.063 (27.00)	0.400 (10.16)	1.263 (32.08)	-163-	-164-	-165-	-166-	-167-	-168-	240.0	.060	240.0	.60	46.0	1.20
0.12	1.063 (27.00)	0.400 (10.16)	1.263 (32.08)	-169-	-170-	-171-	-172-	-173-	-174-	240.0	.072	240.0	.72	44.5	1.34
0.15	1.375 (34.93)	0.400 (10.16)	1.575 (40.01)	-175-	-176-	-177-	-178-	-179-	-180-	240.0	.090	240.0	.83	40.0	1.50
0.18	1.375 (34.93)	0.500 (12.70)	1.575 (40.01)	-277-	-278-	-279-	-280-	-281-	-282-	240.0	.11	240.0	.95	38.0	1.70
0.20	1.375 (34.93)	0.500 (12.70)	1.575 (40.01)	-181-	-182-	-183-	-184-	-185-	-186-	240.0	.12	240.0	1.03	37.0	1.85
0.22	1.375 (34.93)	0.500 (12.70)	1.575 (40.01)	-187-	-188-	-189-	-190-	-191-	-192-	240.0	.13	240.0	1.10	35.0	1.93
0.27	1.375 (34.93)	0.562 (14.27)	1.575 (40.01)	-193-	-194-	-195-	-196-	-197-	-198-	240.0	.16	240.0	1.21	33.0	2.24
0.33	1.375 (34.93)	0.562 (14.27)	1.575 (40.01)	-199-	-200-	-201-	-202-	-203-	-204-	240.0	.20	240.0	1.32	32.0	2.65
0.39	1.875 (47.63)	0.562 (14.27)	2.075 (52.71)	-205-	-206-	-207-	-208-	-209-	-210-	240.0	.23	240.0	1.48	32.0	3.14
0.47	1.875 (47.63)	0.562 (14.27)	2.075 (52.71)	-211-	-212-	-213-	-214-	-215-	-216-	240.0	.28	240.0	1.68	31.0	3.64
0.50	1.875 (47.63)	0.562 (14.27)	2.075 (52.71)	-217-	-218-	-219-	-220-	-221-	-222-	240.0	.30	240.0	1.75	30.0	3.75
0.56	1.875 (47.63)	0.562 (14.27)	2.075 (52.71)	-223-	-224-	-225-	-226-	-227-	-228-	240.0	.34	240.0	1.92	29.0	4.05
0.68	1.875 (47.63)	0.750 (19.05)	2.075 (52.71)	-229-	-230-	-231-	-232-	-233-	-234-	240.0	.41	240.0	2.26	26.0	4.50
0.82	1.875 (47.63)	0.750 (19.05)	2.075 (52.71)	-235-	-236-	-237-	-238-	-239-	-240-	240.0	.49	234.0	2.63	23.4	4.80
1.0	1.875 (47.63)	0.750 (19.05)	2.075 (52.71)	-241-	-242-	-243-	-244-	-245-	-246-	240.0	.60	208.0	3.00	20.8	5.20
1.2	1.875 (47.63)	1.000 (25.4)	2.075 (52.71)	-247-	-248-	-249-	-250-	-251-	-252-	240.0	.72	183.0	3.48	18.3	5.50
1.5	2.375 (60.33)	1.000 (25.4)	2.575 (65.41)	-253-	-254-	-255-	-256-	-257-	-258-	240.0	.90	160.0	4.14	16.0	6.00
1.8	2.375 (60.33)	1.000 (25.4)	2.575 (65.41)	-259-	-260-	-261-	-262-	-263-	-264-	240.0	1.08	150.0	4.69	15.0	6.80
2.0	2.375 (60.33)	1.000 (25.4)	2.575 (65.41)	-265-	-266-	-267-	-268-	-269-	-270-	240.0	1.20	140.0	5.00	14.0	7.00

MIL-PRF-83421/1D

^{1/} L and D dimensions are bare case dimensions (see figure 1).

^{2/} The complete dash number will include the applicable letter completing the style designator (CRH01 = 1, CRH02 = 2, etc.) as a prefix and the applicable FR level symbol (M, P, R, or S) as a suffix.

^{3/} For +125°C operation, linearly derate +100°C rating by 50 percent.

REQUIREMENTS:

Dimensions and configuration: See [figure 1](#) and [table I](#).

Case material: Nonmagnetic (end seals may be of magnetic material).

Leads:

.500 inch (12.70 mm) and smaller case diameters: Composition W and final finish 32 of [MIL-STD-1276](#). Composition N and final finish 32 of [MIL-STD-1276](#) may be furnished when specified in contract or order (see [MIL-PRF-83421](#) ordering data).

.562 inch (14.27 mm) and larger case diameters: Composition C and final finish 32 of [MIL-STD-1276](#).

Capacitance value: See [table I](#).

Capacitance tolerance: See [table I](#).

Rated voltage: AC (see [table I](#)), DC (see [table I](#) and [table II](#)).

TABLE II. DC ratings.

Styles	Volts, dc
CRH01, CRH06	30
CRH02, CRH07	50
CRH03, CRH08	100
CRH04, CRH09	200
CRH05, CRH00	400

Operating temperature range: -65°C to +100°C; derate linearly from +100°C to 50 percent of rated voltage at +125°C.

Failure rate (FR) level: M (1.0%), P (0.1%), R (0.01%), and S (0.001%) (established at dc rated voltage at +100°C).

Burn-in (styles CRH01 through CRH05 only): 140 percent minimum of dc rated voltage shall be applied for 48 hours minimum at +125°C +4°C, -0°C.

Thermal shock: [Method 107 of MIL-STD-202](#), test condition B.

Styles CRH01 through CRH05: 10 cycles.

Styles CRH06 through CRH00: 5 cycles.

Seal: [Method 112 of MIL-STD-202](#), test condition C, procedure IIIa with the following exceptions and details: A bomb pressure of 45 ± 5 lbf/in² (gage), exposure time of 1 hour +1 hour, -0 hour, and dwell time of 1 hour maximum. The reject limit for styles CRH01 through CRH05 is $R_1 = 1 \times 10^{-6}$ atm cm³/s and $R_1 = 1 \times 10^{-5}$ atm cm³/s for styles CRH06 through CRH00. Upon completion of test condition C, perform either test condition A, test condition B with mineral oil, or test condition D.

Dielectric withstanding voltage (DWV): [Method 301 of MIL-STD-202](#).

Terminal to terminal:

AC: 100 Hz \pm 10 Hz square wave, peak-to-peak voltage, three times dc rated voltage for 60 seconds, minimum but need not exceed 800 V peak-to-peak.

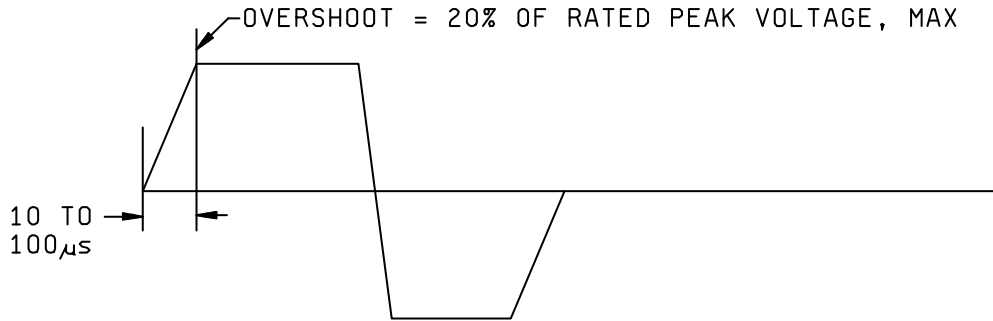

DC: 200 percent of dc rated voltage for 60 seconds, minimum.

Insulation resistance (IR): [Method 302 of MIL-STD-202](#). Charge time 5 minutes, maximum; however, for capacitance values greater than 1.0 μ F, an additional 1 minute per μ F is permitted.

Terminal to terminal (dc rated voltage): See table III.

Terminals to case: 10,000 megohms, minimum.

TABLE III. Insulation resistance versus capacitance value.

Styles	Temperature	Capacitance	Minimum insulation resistance (terminal to terminal)
CHR01, CHR02, CHR03, CHR04, CHR05	+25°C	0 μ F to .1 μ F	3,000,000 megohms
		Greater than .1 μ F	300,000 megohm-microfarads
	+100°C	0 μ F to .1 μ F	300,000 megohms
		Greater than .1 μ F	30,000 megohm-microfarads
	+125°C	0 μ F to .1 μ F	20,000 megohms
		Greater than .1 μ F	2,000 megohms-microfarads
CHR06, CHR07, CHR08,CHR09, CHR00	+25°C	0 μ F to .1 μ F	1,000,000 megohms
		Greater than .1 μ F	100,000 megohms-microfarads
	+100°C	0 μ F to .1 μ F	50,000 megohms
		Greater than .1 μ F	5,000 megohm-microfarads
	+125°C	0 μ F to .1 μ F	10,000 megohms
		Greater than .1 μ F	1,000 megohm-microfarads

Dissipation factor (DF): 0.15 percent maximum.

Dielectric absorption: 0.1 percent, maximum.

Barometric pressure (reduced): [Method 105 of MIL-STD-202](#), condition D (100,000 feet). 125 percent of dc rated voltage applied. See [MIL-PRF-83421](#) for voltage limitations.

Vibration, random (optional): In accordance with [MIL-PRF-83421](#) when ordered with "-" replaced with "H" in the PIN.

Immersion: [Method 104 of MIL-STD-202](#), test condition C.

DWV:

Insulating sleeves: Greater than 4,000 volts, dc.

Terminal to terminal: 200 percent of dc rated voltage.

Terminals to case: 200 percent of dc rated voltage.

IR:

Insulating sleeves: 10,000 megohms, minimum.

Terminal to terminal: Not less than 50 percent of initial requirement.

Terminals to case: 5,000 megohms, minimum.

ΔC :

Styles CRH01 through CRH05: Maximum of ± 0.25 percent.

Styles CRH06 through CRH00: Maximum of ± 1.0 percent.

DF: 0.15 percent.

Moisture resistance: [Method 106 of MIL-STD-202](#).

DWV, IR, ΔC , and DF: Same as for immersion.

Low temperature life: In accordance with [MIL-PRF-83421](#), except measurements shall be made at the following temperatures.

$t_1 = +25^\circ\text{C}$: Record initial capacitance, dissipation factor, and insulation resistance.

$t_2 = -65^\circ\text{C}$: 48 hours, rated dc voltage applied.

$t_3 =$ Maximum operating temperature: 2 hours rated dc voltage applied (allow for derating).

$t_4 = +25^\circ\text{C}$: Record capacitance, dissipation factor, and insulation resistance. Limits of change shall be as specified in table IV.

TABLE IV. Post measurement limits.

t_1 to t_4	Styles CRH01 through CRH05	Styles CRH06 through CRH00
Capacitance	$\pm 0.5\%$	$\pm 1.0\%$
Dissipation factor	0.15% maximum	0.15% maximum
Insulation resistance	Within initial requirements	Within initial requirement

Resistance to soldering heat: [Method 210 of MIL-STD-202](#), condition B.

ΔC : Maximum of ± 0.25 percent.

Temperature coefficient: In accordance with [MIL-PRF-83421](#). Capacitance shall be measured at the temperatures specified in table V.

TABLE V. Capacitance changes.

Temperature ^{1/}	Styles CRH01 through CRH05	Styles CRH06 through CRH00
t ₃ to t ₂	-1.0% to +1.2%	± 2.0%
t ₃ to t ₄	-2.5% to 0%	-2.5% to 0%
t ₃ to t ₁ or t ₅	± .25%	± .25%

^{1/} t₁ = +25°C ±3°C
 t₂ = +125°C ±3°C
 t₃ = +25°C ±3°C
 t₄ = -55°C +0°C, -3°C
 t₅ = +25°C ±3°C

Life (at +100°C): [Method 108 of MIL-STD-202](#).

Accelerated condition: 140 percent of dc rated voltage.

Rated condition: 100 percent of dc rated voltage.

IR:

Terminal to terminal: Not less than 33.3 percent of initial requirement.

Terminals to case: 5,000 megohms, minimum.

ΔC:

Styles CRH01 through CRH05: Maximum of ± 2.0 percent.

Styles CRH06 through CRH00: Maximum of ± 5.0 percent.

DF (at +25°C) after life:

Styles CRH01 through CRH05: 0.25 percent, maximum.

Styles CRH06 through CRH00: 0.35 percent, maximum.

AC conditioning: In accordance with [MIL-PRF-83421](#).

Test samples shall be in accordance with [table VI](#).

| Changes from previous issue: The margins of this specification are marked with vertical lines to indicate where changes from the previous issue were made. This was done as a convenience only and the Government assumes no liability whatsoever for any inaccuracies in these notations. Bidders and contractors are cautioned to evaluate the requirements of this document based on the entire content irrespective of the marginal notations and relationship to the last previous issue.

| Referenced documents: In addition to [MIL-PRF-83421](#), this document also references [MIL-STD-202](#) and [MIL-STD-1276](#).

Custodians:

| Army - CR
Navy - EC
Air Force - 85
DLA - CC
NASA - NA

Preparing activity:

DLA - CC

(Project 5910-2008-027)

Review activities:

Army - AR
Navy - AS, MC, OS, SH
Air Force - 19

NOTE: The activities listed above were interested in this document as of the date of this document. Since organizations and responsibilities can change, you should verify the currency of the information above using ASSIST Online database at <http://assist.daps.dla.mil/>.